

Invited Comment

The birth of attosecond physics and its coming of age

Ferenc Krausz

Max-Planck-Institut für Quantenoptik, Hans-Kopfermann-Strasse 1, D-85748 Garching, Germany
Fakultät für Physik, Ludwig-Maximilians-Universität, Am Coulombwall 1, D-85748 Garching, Germany

E-mail: Ferenc.Krausz@mpq.mpg.de

Received 27 October 2015, revised 17 December 2015

Accepted for publication 29 December 2015

Published 25 May 2016



CrossMark

Abstract

Classical electromagnetism allows the rapidity of light field oscillations to be inferred from measurement of the speed and wavelength of light. Quantum mechanics connects the rapidity of electronic motion with the energy spacing of the occupied quantum states, accessible by light absorption and emission. According to these indirect measurements, both dynamics, the oscillation of light waves as well as electron wavepackets, evolve within attoseconds. With the birth of attosecond metrology at the dawn of the new millennium, light waving and atomic-scale electronic motion, being mutually the cause of each other, became directly measurable. These elementary motions constitute the primary steps of any change in the physical, chemical, and biological properties of materials and living organisms. The capability of observing them is therefore relevant for the development of new materials and technologies, as well as understanding biological function and malfunction. Here, I look back at milestones along the rocky path to the emergence of this capability, with some details about those my group had the chance to make some contributions to. This is an attempt to show—from a personal perspective—how revolution in science or technology now relies on progress at a multitude of fronts, which—in turn—depend on the collaboration of researchers from disparate fields just as on their perseverance.

Keywords: quantum optics, international year of light, attosecond physics

‘Manfred Eigen, then director of the Max Planck Institute for Biophysical Chemistry in Göttingen, Germany, accepted the 1967 Nobel prize in chemistry with a lecture about his work on ‘immeasurably fast reactions’. Ahmed Zewail, recipient of the 1999 Nobel prize in chemistry, who analyzed reactions over timescales a billion times shorter than Eigen, later joked about this title. If attosecond techniques do become reality, the immeasurable will have to be redefined once again’. I cited these sentences from a feature article of Yudhijit Bhattacharjee entitled ‘Measuring the Immeasurable’ and published in *Nature* [1] in August 2001. Several weeks later, the first observation of isolated attosecond pulses was reported [2].

Attosecond technology almost abruptly improved the temporal resolution of time-resolved spectroscopy by two

orders of magnitude, following a one and a half decade long stagnation in resolving fastest microscopic phenomena. By doing this, it rendered a wealth of previously immeasurably fast microscopic phenomena driven by electronic motions measurable [3]. It is instructive to review the conceptual and experimental advances that laid the groundwork for the birth of attosecond science, revealing the need for progress on many frontiers to allow such a revolution in technology to happen. This article attempts to pay tribute to those who pushed the relevant frontiers with its author being aware that the work of many more may have deserved to be appreciated than possible in the framework of this essay. My apologies go to all those whose important work could not be explicitly acknowledged below.

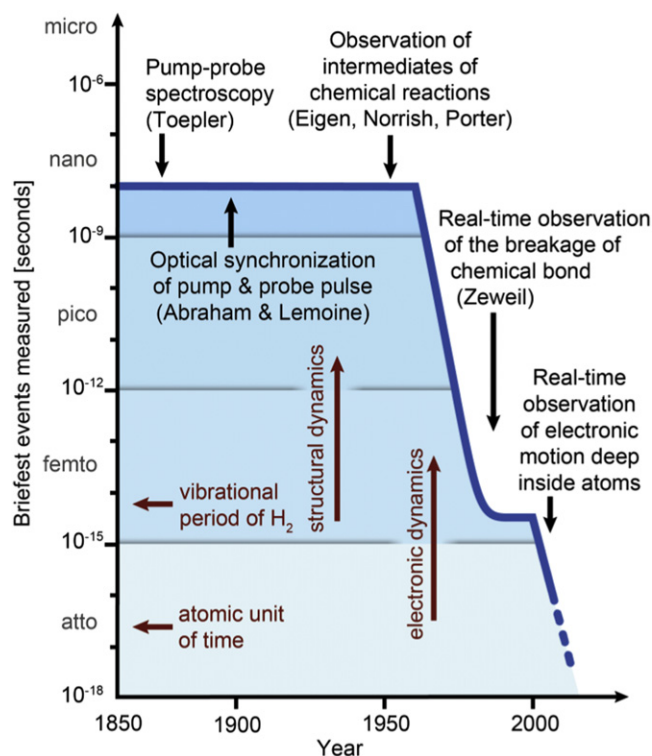

Figure 1. Evolution of techniques for real-time observation of microscopic processes. Discontinuities in the slope of briefest measured events versus years indicate revolutions in technology.

Capturing microscopic processes—early developments

In 1864, Toepler extended spark photography, already known as a method for recording rapid motion of macroscopic objects, to study microscopic dynamics [4]. He generated sound waves with a short light spark and subsequently photographed them with a second spark that was delayed electronically with respect to the first one initiating the motion. By taking pictures of the sound wave as a function of the delay time, he obtained a complete history of sound-wave phenomena. The pump–probe technique was born. In 1899, Abraham and Lemoine improved the technique by deriving the pump and probe flash from the same spark with a variable optical delay between them, improving the resolution of pump–probe spectroscopy to the limit dictated by the flash duration [5]. With these milestones, the conceptual framework for studying transient microscopic phenomena was complete. Subsequent progress was driven—for about hundred years, until the end of the XXth century—by producing ever shorter flashes and techniques for their measurement.

The first revolution: laser pulses for pump–probe spectroscopy

The resolving power of pump–probe techniques was limited by the nanosecond duration of light pulses for more than half a century, before laser-based techniques improved it by six

orders of magnitude within merely two and a half decades (figure 1). Femtosecond laser pulse generation and measurement techniques permitted—four decades after the observation of intermediates of chemical reactions by Norrish and Porter [6] and Eigen [7]—real-time observation of the breakage and formation of chemical bonds, a field triggered by the pioneering work of Zewail [8, 9].

Progress in temporal resolution was again halted in the mid-1980s, when the duration of the shortest laser pulses approached the several-femtosecond oscillation period of the lightwave carrying the pulse. Two approaches have been considered for breaking this barrier: (A) phase locking of coherent optical waves over several octaves to produce sub-cycle optical transients over the visible (VIS) and near-infrared (NIR) [10–13] and (B) high-order harmonic generation (HHG) [14–17] and their coherent combination to create several-cycle pulses in the extreme ultraviolet (XUV) [18–20]. In principle, both concepts permit pushing the frontiers of pump–probe spectroscopy into the sub-femtosecond and attosecond regime. In practice, none of them worked, at least initially, for entirely different reasons. (A) Failed because of the lack of precision multi-octave dispersion control which is required to synthesize a bandwidth-limited pulse over a multi-octave spectral range and (B) provided pulses too weak to be measured by standard nonlinear autocorrelation techniques and utilized for both triggering and probing ultrafast phenomena (i.e. being used both as a pump and as a probe pulse). These failures had the resolving power of ultrafast spectroscopy stagnated over one and a half decade long at a level of several femtoseconds (figure 1). Again, a radically new approach was required to end stagnation.

The second revolution: controlling electrons with the field of light

The second discontinuity in the rate of progress of capturing ultrafast processes occurred around the turn of the millennium (figure 1) and was brought about by the use of the electric field of light for controlling electrons on sub-femtosecond time scales. This enabled the generation and measurement of isolated sub-femtosecond pulses of XUV light. With the full control of the electric field of VIS/NIR laser light changing its strength and direction within attoseconds, subsequently XUV flashes shorter than 100 as became routinely available. These attosecond pulses come in perfect synchronism to the controlled electric field waveform of the VIS/NIR laser pulse used for its generation. Hence, the attosecond electric force of light has been able to replace the weak XUV pulse either as a pump or as a probe in the scrutiny of microscopic dynamics, furnishing the century-old pump–probe spectroscopy with a resolution permitting direct observation of electronic motions for the first time. In what follows I shall briefly review the major milestones in laser physics that allowed this to happen. I will address in more detail those my group has been directly involved in along with the (often quite cumbersome) struggles that preceded relevant progress.

Early milestones: femtosecond solid-state lasers and high-order harmonics

As already mentioned above, the invention of the lasers along with nonlinear optical techniques for generating and measuring short pulses from them entailed the improvement of the resolving power of pump–probe spectroscopy from nanoseconds to femtoseconds by the mid 80's. This first revolution provided direct time-domain access to the chemical-bond-scale motion of atoms, allowing real-time observation of dynamic changes in molecular and crystalline structure (figure 1). Whilst this key performance indicator stagnated over the following one and a half decades, many important developments occurred during this period that laid the groundwork for the second revolution, which opened the door for observing electronic phenomena.

Laser pulses as short as 6 fs [21] could be produced and measured by the mid 80s. They originated from first-generation femtosecond lasers employing organic dyes as the active medium [22]. Their nanojoule-scale energy was insufficient to extend ultrashort-pulse generation to much shorter wavelengths via nonlinear frequency conversion. To this end, femtosecond pulse generation needed to be scaled to millijoule-scale energies, by some 4–5 orders of magnitude. The prerequisites for this progress were created by three great inventions, (i) the broadband solid-state laser medium, titanium-doped sapphire (Ti:S) by Peter Moulton [23], (ii) 'self mode locking' (later referred to as Kerr-lens mode locking, KLM) by Wilson Sibbett and coworkers [24] and (iii) chirped-pulse amplification (CPA) by Gerard Mourou and coworkers [25, 26]. These inventions spawned the second generation of femtosecond technology based on solid-state (primarily Ti:S) laser media and capable of scaling the peak as well as the average power of femtosecond laser pulses by several orders of magnitude with respect to first-generation technology [27].

Parallel to these achievements, inspired by Charles Rhodes and coworkers [14], Anne L'Huillier and coworkers demonstrated, in a series of pioneering experiments, the feasibility of extending the generation of coherent radiation from the VIS/IR spectral range (covered by lasers) to several orders of magnitude shorter wavelengths, well into the XUV, via HHG by powerful ultrashort laser pulses from solid-state lasers [28–32]. With Ti:S lasers entering the scene, HHG became a standard approach to extending coherent radiation into the vacuum and XUV regime [16]. Although coherent superposition of the harmonics generated at the highest harmonic photon energies were predicted to yield attosecond bursts [20], the multi-cycle nature of the driver pulses implied that even if these bursts existed, they must have come in the form of PHz-repetition-rate trains extending over a period comparable to that of the driver pulse. Opening the attosecond shutter of an 'attosecond camera' every femtosecond many times after each other apparently greatly limited its utility for capturing electronic phenomena which often unfold within attoseconds but extend over femtoseconds.

The importance of isolating a single attosecond burst for spectroscopic applications was recognized shortly after HHG

driven by Ti:S lasers yielded broadband coherent XUV emission [16] the time structure of which was measured to exhibit bursts of attosecond pulses many years later [33]. Nevertheless, it took quite a few years to actually provide the experimental means for performing this feat. It required the control of the evolution of the electric field of light on a time scale of the field oscillation period. In a first step, one needed to make the cycles of a strong-field ultrashort laser pulse distinguishable. The most straightforward approach to this is to shorten the pulse duration to a value comparable to the carrier wave cycle. To complete control, one needed to gain full control over the waveform in a second step. Our group was involved in both steps and I comment in more detail on these steps to pay tribute to those colleagues involved in realizing them and to show that persistence—on the long run—pays off in science just as it does in other areas of life.

Making field cycles of powerful laser light distinguishable

The first Kerr-lens-mode-locked (KLM) Ti:S laser produced pulses of 60 fs duration [24], more than an order of magnitude longer than the Fourier-limit dictated by the bandwidth of the gain medium (stretching over 600–1100 nm) [23]. Recognizing that the actual pulse duration was limited by higher-order dispersion introduced by the prism sequence incorporated in the cavity for group-delay-dispersion (GDD) control [34, 35], intense research began to select the best possible prism material for minimizing this undesirable high-order dispersion. By the early 90s this research, work of Margaret Murnane [36], Frank Wise [37] and their coworkers, and that of our group [38] led to 10 fs-scale laser pulses (carried at a wavelength of about 800 nm) from KLM Ti:S lasers in which GDD control was implemented by low-loss Brewster-angled prisms selected for minimum high-order dispersion. Since the neighboring central field cycles differ only by a few percent in amplitude in such a pulse, significantly shorter pulses were needed to isolate a single laser cycle for extreme nonlinear optics and attosecond science.

Motivated by this goal, our collaborators Robert Szipöcs and Kárpát Ferencz from Budapest came up with the idea to develop and utilize multilayer mirrors for not only providing feedback by high reflectivity over the required bandwidth but also tailored dispersion for shaping the pulse emerging from the mode-locking process in the laser cavity. The project started back in 1991 with pertinent design efforts by Robert and was followed by several attempts to manufacture the designed prototypes. As a result of these struggles, by late 1992 we had the first mirrors with aperiodic multilayer structures (which later became known as 'chirped mirrors', figure 2) at hand, which appeared promising enough to be tested in a Kerr-lens-mode-locked Ti:S laser oscillator. This attempt proved unsuccessful, just as numerous other following ones. Whilst the mirrors offered a great return in form of more bandwidth with well-behaved dispersion and a much more compact and robust laser, they suffered from a severe shortcoming, too: unlike the prism pair routinely used in

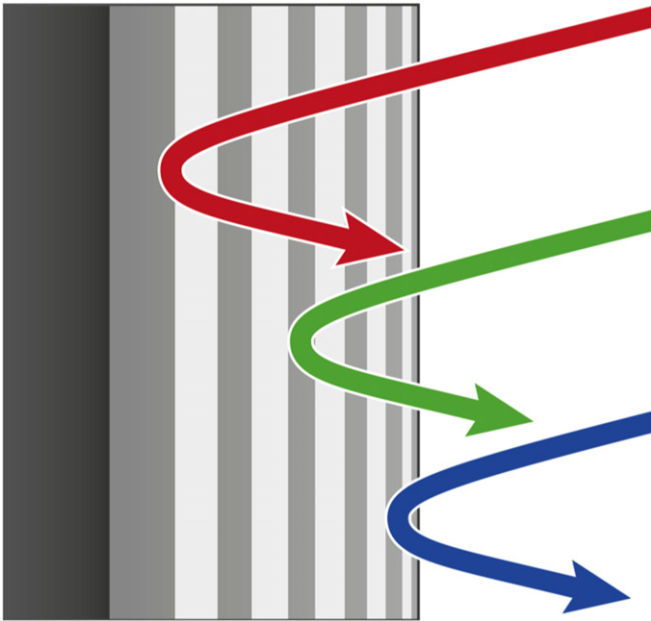

Figure 2. Schematic illustration of the origin of group-delay dispersion (GDD) in a chirped multilayer mirror. Narrow-band wave packets carried at different wavelengths penetrate to different depths before being reflected, as a consequence of a modulation of the multilayer period across the layer stack. In the illustrated example, the increasing multilayer period with increasing distance from the mirror surface implies that radiation with increasing wavelength has to penetrate deeper before being reflected. The result is a group delay that raises with increasing wavelength, i.e., decreasing frequency, giving rise to negative GDD, which is needed in laser oscillators and pulse compressors to compensate for the chirp imposed by self-phase modulation and material dispersion.

femtosecond oscillators for GDD control, they did not provide any degree of freedom for adjusting the GDD. This capability was crucial in prism-controlled systems, it allowed to set the negative GDD first to a higher value to facilitate soliton-like pulse build-up in the mode-locked laser and then minimize it for minimum steady-state pulse duration.

Andreas Stingl and Christian Spielmann, the first experimentalists under my supervision, spent numerous days and nights over many months in our laboratory, just as Robert and Kárpát spent on developing mirrors with improved characteristics before the first mirror-dispersion-controlled femtosecond laser (based on Ti:sapphire as the active medium and employing KLM as the mode locking mechanism) could eventually be successfully demonstrated in the summer of 1993 [39, 40]. As is often the case in science, serendipity played a role in the breakthrough: the unavoidable GDD fluctuation (versus wavelength) of chirped mirrors led, with a specific combination of mirrors, to an overall GDD curve that exhibited enhanced negative GDD over a narrow spectral range around the wavelength of the free-running laser (relevant at the beginning of the mode locking process). This dip in the GDD curve facilitated soliton-like pulse build-up, whilst the substantially lower average GDD over the mirror bandwidth ensured a very short steady-state pulse duration. Serendipity was helpful but did not come accidentally, it was compelled by perseverant search for the solution.

Thanks to the dramatic improvement of the efficiency of the KLM-based self-amplitude modulation owing to the pioneering theoretical work of Hermann Haus [41] and Thomas Brabec [42] as well as subsequent improvements of the bandwidth and flatness of GDD of chirped mirrors by Robert Szipöcs [43], Franz Kärtner [44], Gabriel Tempea [45], mirror-dispersion-controlled Ti:sapphire laser technology rapidly entered the sub-10 fs regime [46]. With semiconductor saturable absorbers pioneered by Ursula Keller they became self starting and outperformed any other femtosecond oscillator technology [47, 48]. The new technology rapidly proliferated all over the world and spawned, up to the present day, the only commercially available sub-10 fs laser oscillator, with the shortest pulses approaching the gain bandwidth limit of Ti:S, below 5 fs [49].

The power of these typically several-nanojoule-energy pulses have been boosted in Ti:sapphire chirped pulse amplifiers into the millijoule regime. However, gain narrowing in these amplifiers limited the duration of such pulses to about 20 fs from the high-power systems. The invention of gas-filled hollow-core fibers for spectral broadening of high-energy pulses via self-phase modulation by Orazio Svelto and Sandro de Silvestri from Milano [50] and subsequent compression of the self-phase-modulated pulses by chirped mirrors have spawn the first powerful few-cycle pulses of laser light [51].

With this milestone the above mentioned goal, the isolation of a single cycle of strong laser field, was achieved. Indeed, in a laser pulse confining about 1.5 field cycles within its full width of intensity half maximum, the amplitude of the central wave cycle exceeded that of neighboring cycles by some 20%. Whenever the laser-field driven process (e.g. strong-field ionization) was a highly nonlinear function of the strength of the laser electric field, a few-cycle pulse, made available by the above mentioned advances, permitted *confinement of the interaction to a single field cycle*, constituting an unprecedented amount of control of strong-field-matter interactions. However, this was not yet entirely satisfactory for sub-cycle (attosecond) control of laser–electron interactions. Uncontrolled shifts of the phase of the carrier-wave with respect to the amplitude envelope (dubbed carrier-envelope phase, CEP) of the pulse led to small variations in the sub-cycle evolution of a few-cycle laser field (figure 3) and might cause significant pulse-to-pulse variations in the evolution of the electron processes triggered and driven by these fields. Apparently, this deficiency needed to be fixed.

Controlling the field of light: laser pulses with reproducible waveform

The quest for controlled light waveforms started in 1996 with the first study of the pulse-to-pulse variation of the CEP in the train of ultrashort light pulses from a femtosecond laser oscillator [52] with the goal realized seven years later [53]. Whilst the control of the pulse-to-pulse CEP-shift could already be demonstrated in the early work, in order to achieve full control over the CEP and thereby the waveform of

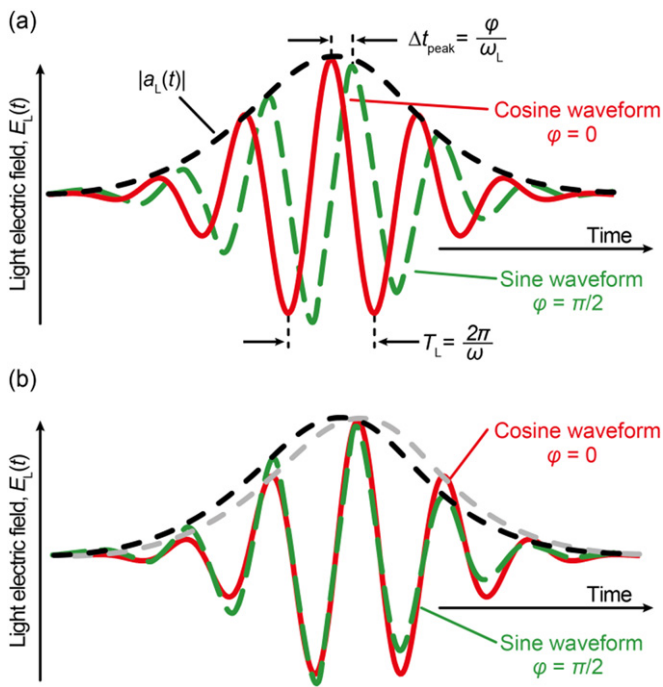

Figure 3. Few-cycle laser pulses containing two oscillation cycles within the full width at half maximum of their intensity profile, with sine- and cosine-shaped waveforms, with their (a) amplitude envelopes and (b) field oscillations coinciding.

individual pulses we utilized the frequency-comb technique of my colleague, Theodor Hänsch, who received the 2005 Nobel Prize for this invention [54].

The work that brought about this breakthrough had resulted from a collaborative effort between groups representing two communities (time-domain and frequency-domain metrology) that had little to do with each other before. As a matter of fact, the work of Baltuska *et al* [53] did not only report on controlled strong light fields for the first time and demonstrated their relevance for attosecond science. Likewise, it represents a culmination of synergies between frequency-domain and time-domain techniques, resulting from a fruitful collaboration of the two communities that continues up to the present day. The benefits are mutual: octave-spanning laser mode locking provides a ‘ruler’ for precision frequency metrology, whereas a frequency-domain self-referencing technique invented by Theodor Hänsch opened the door to controlling the electric and magnetic fields of ultrashort light pulses.

Isolated attosecond pulses and their first applications

First experimental hints at isolated sub-femtosecond pulses appeared in 1997, when Christian Spielmann and coworkers generated high-order harmonics in neon with few-cycle laser pulses [55]. The highest-order (cut-off) harmonics were observed to coalesce, suggesting the absence of periodicity, i.e. the temporal confinement of cut-off radiation to a fraction

of the half cycle of the driving laser field. However, it took us several years to deliver the ‘smoking gun’ for the existence of isolated pulses shorter than 1 fs. To this end, we had to extend the relatively simple setup for generation (left-hand side of figure 4) with an instrument for temporal characterization (right-hand side of figure 4). The two-component mirror incorporating a nanometer-precision delay stage has been a key component enabling the few-cycle NIR pulse generating the XUV high-harmonic pulse to be delayed with respect to the XUV pulse with attosecond accuracy. Our collaborators from Bielefeld (Germany), Ulf Kleineberg, Markus Drescher and Ulrich Heinzmann have developed both the Mo/Si multilayer coating reflecting the 90–95 eV XUV and the 1.2–2.0 eV NIR radiation for the mirror and the time-of-flight (TOF) spectrometer.

The TOF electron energy analyzer was central for implementing the concept originally proposed by Paul Corkum (NRC Canada, Ottawa) for measuring a short XUV pulse: having photoelectrons from atoms released in the presence of a strong laser field serving as a chronoscope by decelerating or accelerating the electrons, depending on their moment of release (figure 5). These collaborations and several years of preparation allowed the first attosecond streaking experiment to be carried out in Vienna in 2001. Michael Hentschel and Reinhard Kienberger have succeeded in recording the first attosecond streaking trace (figure 6) during the night from 10 to 11 September 2001.

It was beyond description to see chronoscopy working on the sub-femtosecond scale and revealing an isolated sub-1 fs flash of XUV light in the morning of 11 September (unfortunately, our elation was dramatically damped by the news from New York several ours later). The manuscript [2] reporting ‘the first attosecond measurement’ [56] was accepted for publication within 18 days and featured in newspapers all over the world.

In their first application, these sub-femtosecond flashes measured the lifetime of an atomic inner-shell vacancy a year later [57] (figure 7) and these accomplishments have been highlighted among the most important breakthroughs of the year of 2002 by the editors of Nature [58] and Science [59].

Precision attosecond metrology

It took yet another year to get the waveform of intense few-cycle laser pulses under control. The resultant strong laser fields with a precisely controlled sub-cycle (e.g. sub-femtosecond) temporal evolution have been decisive for both the reproducible generation [53] and precision measurement of isolated attosecond pulses [60] as well as of the few-cycle waveforms driving them [61].

Again, these feats would not have been feasible without collaborations and full dedication and persistence of a number of colleagues. Thomas Udem, Theodor Hänsch and coworkers provided invaluable support in measuring and stabilizing the CEP for waveform control, whereas Paul Corkum’s idea about an attosecond streak camera served as a basis for the temporal characterization of the tools. Equally

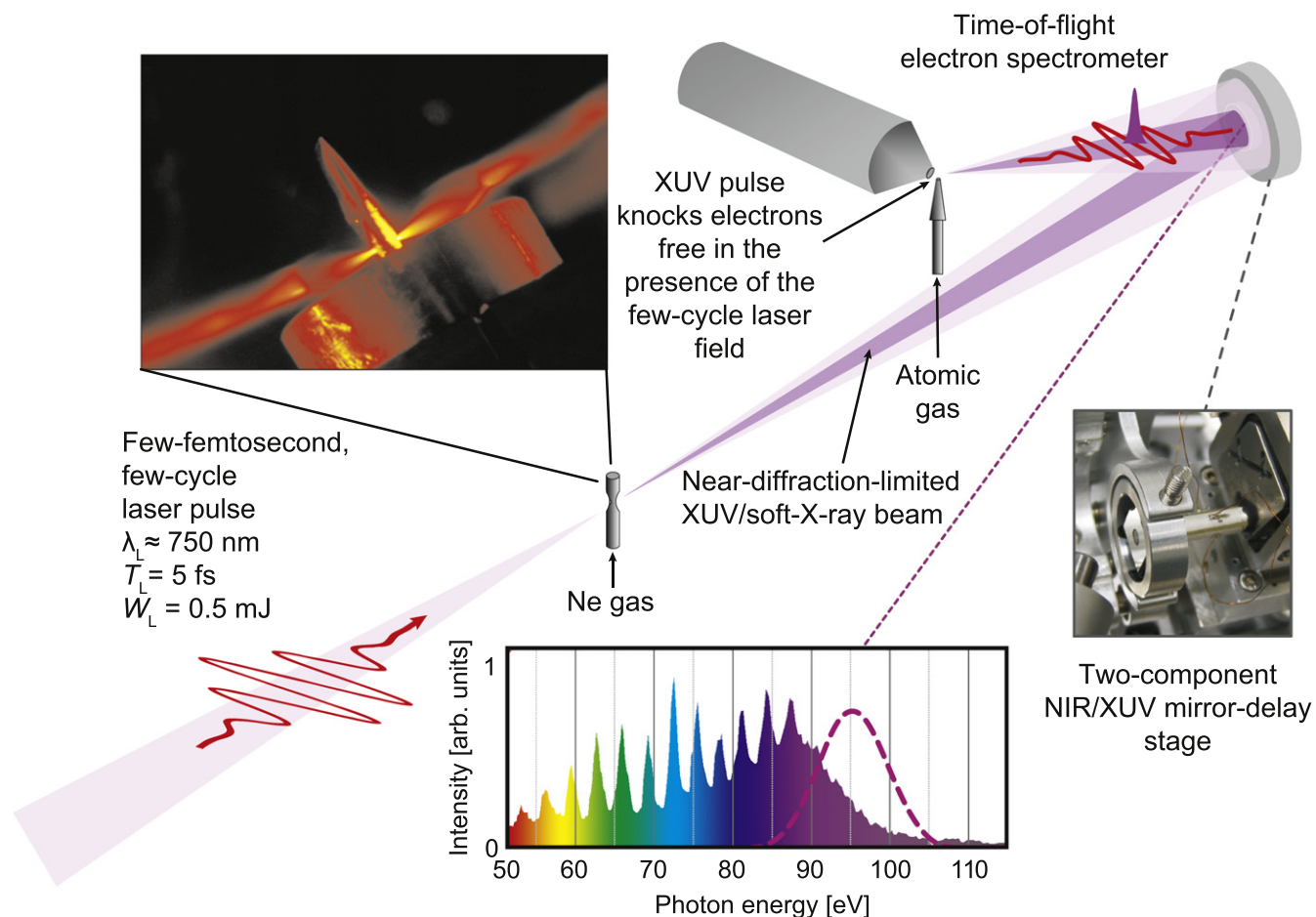

Figure 4. Schematic illustration of the experimental apparatus set up at the Vienna University of Technology and used for the generation, measurement and first applications of isolated sub-femtosecond light pulses. A few-cycle laser pulse generates high-order harmonics in a neon gas medium the cut-off spectral part of which is filtered out by the molybden–silicon multilayer mirror, which also focuses, via two independent concentric parts, both the few-cycle laser beam and the generated XUV burst into a second target. Nanometer-accuracy relative positioning of the two mirror parts permits delaying the XUV burst with respect to the few-cycle laser field previously used for its generation. The apparatus can be used both for temporally characterizing the laser field and the XUV pulse by attosecond streaking as depicted in figure 5 and, subsequently, for real-time observation and control of electronic motions.

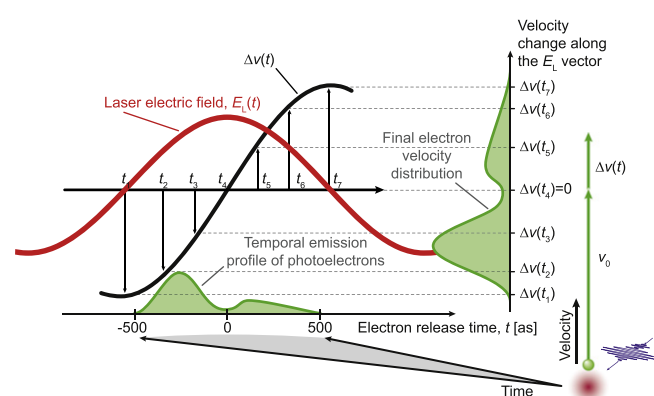

Figure 5. Concept of optical-field-driven attosecond streaking. Photoelectrons released in a laser field parallel to the direction of electric field suffer a change of their initial velocities that is proportional to the vector potential of the field at the instant of release. This function is monotonic within a half wave cycle of the field, mapping the intensity profile of a sub-fs XUV pulse into a corresponding final velocity (or energy) distribution of photoelectrons.

importantly, Alexander Apolonsky, Andrius Baltuska, Eleftherios Goulielmakis, Reinhard Kienberger and Michael Hentschel pushed laser technology to its limit to make these breakthroughs happen.

Attosecond technology and spectroscopy coming of age

Attosecond streaking quickly established itself as a ‘gold standard’ of attosecond metrology, not only for characterization of the key attosecond tools, waveform-controlled few-cycle laser fields and attosecond XUV pulses, but also for probing electron processes with these tools on attosecond-to-femtosecond time scales [62–64]. The temporal information about these phenomena triggered by an isolated attosecond XUV pulse and captured by the few-cycle laser field via attosecond streaking, or—analogously—triggered by a train of attosecond bursts and captured by multi-cycle laser fields via spectral interferometry [65–70], is encoded in the

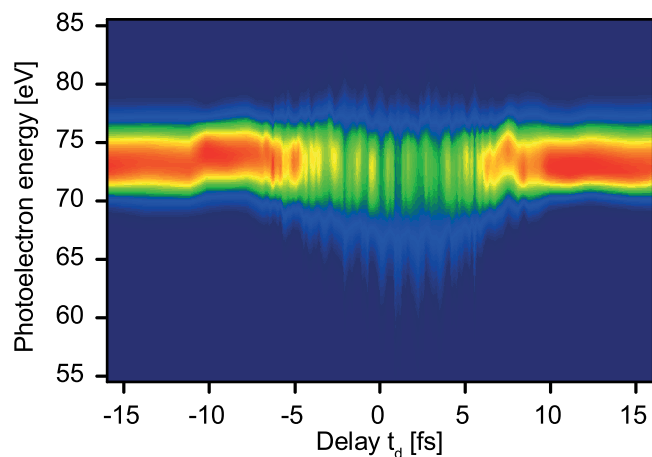

Figure 6. First attosecond streaking spectrogram recorded by the apparatus sketched in figure 4. The spectrogram consists of a series of energy distributions (shown in false color plots) of photoelectrons released by the XUV pulse and modified ('streaked') by the rapidly varying electric field of few-cycle NIR laser pulse previously used for the generation of the XUV pulse as a function of delay between the XUV and the NIR pulse. In this first experiment, the direction of the streaking electric field was set perpendicular to the initial velocity of the electrons (selected by the alignment of the time-of-flight detector) but otherwise the measurement relied on the same basic concept sketched in figure 5. Whilst the parallel detection geometry shown in figure 5 results primarily in an up- and down-shift of the photoelectron energy spectra, the dominant effect of the field in the orthogonal geometry is a broadening and narrowing of the spectrum depending on the delay. In both cases, the series of streaked spectra allows retrieval of the temporal evolution of the laser electric field and the intensity profile and chirp of the attosecond XUV pulse. For more details see [2, 60].

properties of photoelectrons released by the XUV pulse in the presence of the laser field. The more electrons of this kind are delivered per second the faster and the more reliably attosecond metrology can be performed.

Today, more than a decade after the first experiments, it is hard to imagine that the first streaking spectrograms [2] could be recorded at a photoelectron count rate of some 6 electrons/second. State-of-the-art Ti:sapphire laser technology [71] meanwhile offers count rates up to and beyond 10 000 electrons/second (from a gas of neon atoms, the standard target in an attosecond streak camera), permitting the recording of a streaking spectrogram within *less than a minute* and with a signal-to-noise level much higher than offered by the first measurements lasting *several hours*. The technological advances that have permitted this progress also increased the sensitivity of attosecond spectroscopy correspondingly, allowing, very recently, the first attosecond measurements to be performed in helium and providing a direct time-domain insight into the interaction of the two electrons during ionization [72].

The strong-field laser waveforms can also be used as a 'starter gun' to release electronic motions. Two different methods established themselves for probing these motions in real time.

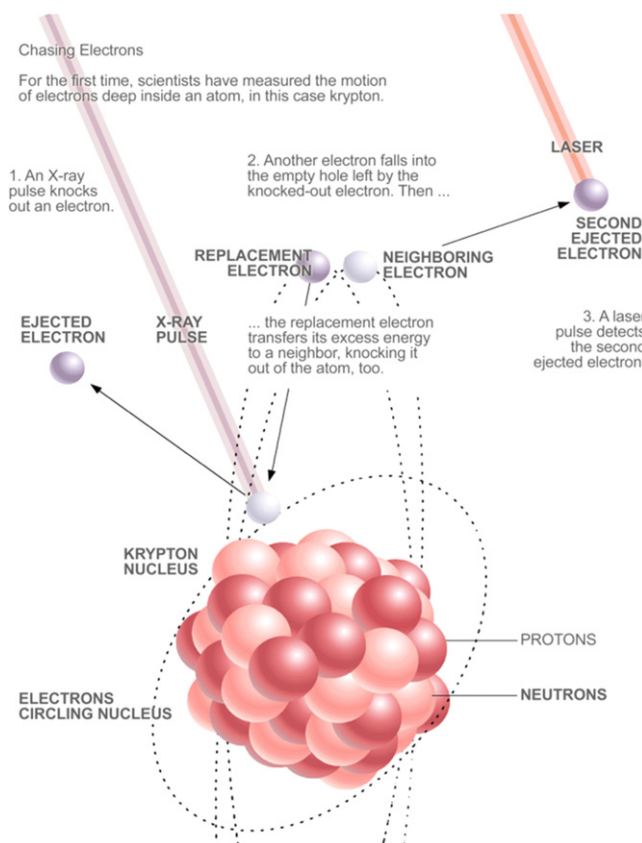

Figure 7. First attosecond time-resolved measurement of electronic motion deep inside an atom (using the apparatus and concept shown in figures 4 and 5). An attosecond XUV ('x-ray') pulse liberates an electron from an inner shell of the electronic system of a krypton atom. The created vacancy survives for an extremely short period of time: within several femtoseconds, i.e. several thousand attoseconds it is filled with an electron from an outer shell. This electron, upon doing this, transfers its excess energy to another outer electron that is thereby catapulted from the atom. The resultant secondary electron emission lasts as long as it takes the vacancy to be filled. Hence, measuring the temporal evolution of this secondary electron emission with a delayed few-cycle laser field via attosecond streaking reveals the lifetime of the inner-shell vacancy just as streaking of the emission of primary photoelectrons yields the duration of the attosecond XUV pulse. Figure reproduced with permission. Copyright PARS International Corp.

(A) The electrons released via ionization in a linearly-polarized field return to their parent ion and their recollision results in high-order harmonic emission [73–76] and electron diffraction [77] that are sensitive to changes in the state of the electronic system during the excursion of the electron. The usage of the recolliding sub-femtosecond electron wavepacket for probing these changes was pioneered by Paul Corkum, Manfred Lein and Jon Marangos and the method has been successfully used for studying electron dynamics in a number of ionizing systems [73–86].

(B) The isolated attosecond XUV pulses offer even more flexibility for probing electron dynamics induced by strong laser fields. XUV probe pulses as short as 80 as [87] and meanwhile even less than 70 as [88] in second-generation beamlines (figure 8) have provided unprecedented real-time insight into fundamental phenomena such as electron

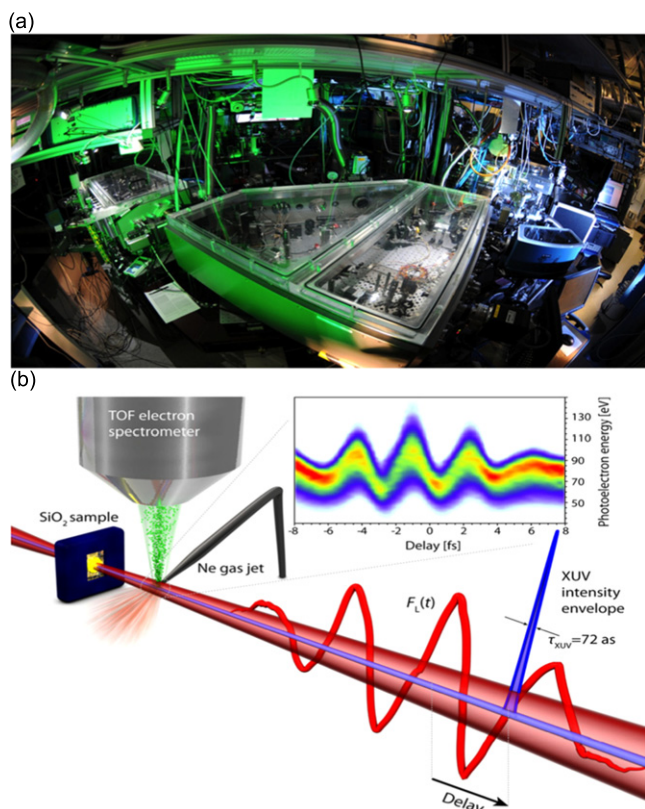

Figure 8. Second-generation attosecond beamline at the Max Planck Institute of Quantum Optics (a) uses sub-4 fs waveform-controlled laser pulses and near-70 as XUV pulses for the time-resolved investigation of ultrafast electron processes (b). The tools are temporarily characterized by attosecond streaking (see recorded attosecond streaking spectrogram) and subsequently used for pump-probe spectroscopy, e.g. for the scrutiny of strong-field-induced electron processes in dielectrics, by means of attosecond XUV absorption spectroscopy. Courtesy of Thorsten Naeser panel (a) copyright IOP Publishing and Martin Schultze panel (b). Copyright Nature Publishing Group 2012.

tunneling [89], valence electron wavepacket dynamics [90, 91] and, more recently, strong-field-induced processes in solids [92–94]. Controlling the waveform of few-cycle pulses was also further advanced to the super-octave synthesis of light transients [95], which recently culminated in the demonstration of optical pulses with a duration of less than 1 fs [96] and provides a force engineerable on an attosecond time scale for steering atomic-scale electron motions. Such short optical pulses also open the door to sub-fs-pump/sub-fs-probe spectroscopy for the first time.

Presence-state of the art

In spite of all the progress reviewed above, the state of the art of attosecond physics is far from getting even close to exploiting the potential it offers for exploring microscopic phenomena. Synthesized optical waveforms of sub-cycle-to-few-cycle light [95, 96] and isolated attosecond XUV pulses have been providing unprecedented insight into a number of electron processes in atoms, molecules and condensed-matter

systems, as well as an ever increasing control over their evolution and outcome. But there is a large number of phenomena and physical questions that cannot be addressed with the current tools. Dynamics involving transitions with small cross sections and/or bound states separated by more than several electronvolts in energy have remained largely inaccessible just as the temporal evolution of the electrons' probability distribution in atomic systems and the related picometer-scale (mean) electron trajectories. The effect of tailored light forced on the outcome of electron dynamics has remained modest, mainly due to the limited variety of waveforms being made available by the limited bandwidth (2 octaves) of current-generation optical waveform synthesizers.

These deficiencies unveil the frontiers where attosecond technology can and needs to be further advanced: the power and photon energy range of attosecond pulses and the bandwidth of optical field synthesizers. The attosecond technology living up to these expectations will be so radically different that it deserves the attribute 'next-generation'.

Future-next-generation attosecond technology

Attosecond technology is based on cutting-edge femtosecond technology. This has so far been provided by Ti:sapphire-based laser systems supplemented with nonlinear pulse compression techniques to overcome the gain-bandwidth limit in our strive for super-octave waveform generation. This few-cycle laser technology has now closely approached its limits in terms of average and peak power, in the range of several watts and a fraction of a terawatt, respectively. Revolutionizing attosecond technology hence calls for a new generation of femtosecond technology, which is capable of scaling both the average and the peak power of few-cycle laser pulses by several orders of magnitude. The only approach offering sufficient gain and scalability over the required bandwidth is optical parametric chirped-pulse amplification (OPCPA).

Although parametric amplification has been known for decades, powerful, efficient and cost-effective picosecond sources, required for pushing the process further ahead, have been unavailable. Thanks to major advances over the past several years triggered by Thomas Metzger at MPQ and continued by Thomas Nubbemeyer at the Ludwig Maximilians University with crucial support of Klaus Wallmeroth and Dirk Sutter from Trumpf Laser GmbH Laser, diode-pumped ytterbium-doped solid-state lasers based on thin-disk geometry (figure 9) are now able to offer near-1 ps pulses at kilowatt-scale average power levels, demonstrated by 10 mJ pulses at 100 kHz and 150 mJ pulses at a 5 kHz repetition rate [97]. The technology is scalable beyond the kilowatt average power level and up to multi-terawatt peak powers [98].

This unique performance comes in combination with the reliability of industrial lasers and renders this technology the best candidate for pumping high-power, ultra-broadband OPCPA systems. Yb:YAG-laser-driven multi-channel broadband OPCPA systems offer the potential for vastly outperforming previous-generation femtosecond technologies

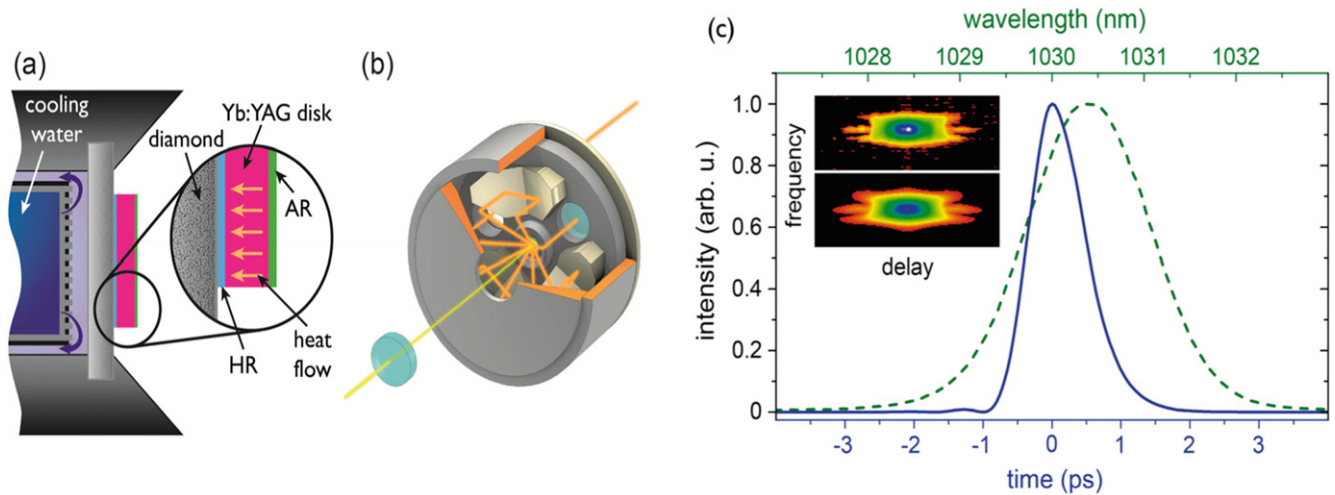

Figure 9. Schematics of thin-disk laser technology. (a) Cold finger with substrate showing the cooling mechanism in a disk laser head, (b) disk laser head showing the principle of the pump light reimaging technique onto the thin-disk active medium (courtesy of TRUMPF Laser GmbH). (c) Measured spectrum (green dashed line) and temporal intensity profile (blue line) from a system equipped with two disk modules (disk parameters: doping concentration $>7\%$, thickness $\sim 100\ \mu\text{m}$, beveled and roughened edge, TRUMPF Laser GmbH). These $0.97\ \text{ps}$ pulses carry energy of $40\ \text{mJ}$ at a repetition rate of $5\ \text{kHz}$, corresponding to an average power of $200\ \text{W}$. The corresponding measured (top) and reconstructed (bottom) FROG traces are shown as insets. Source: Fattahi *et al* 2014 *Optica* 1 45. The system is currently being upgraded to $200\ \text{mJ}$ pulse energy for driving the multi-channel OPCPA system outlined in figure 10.

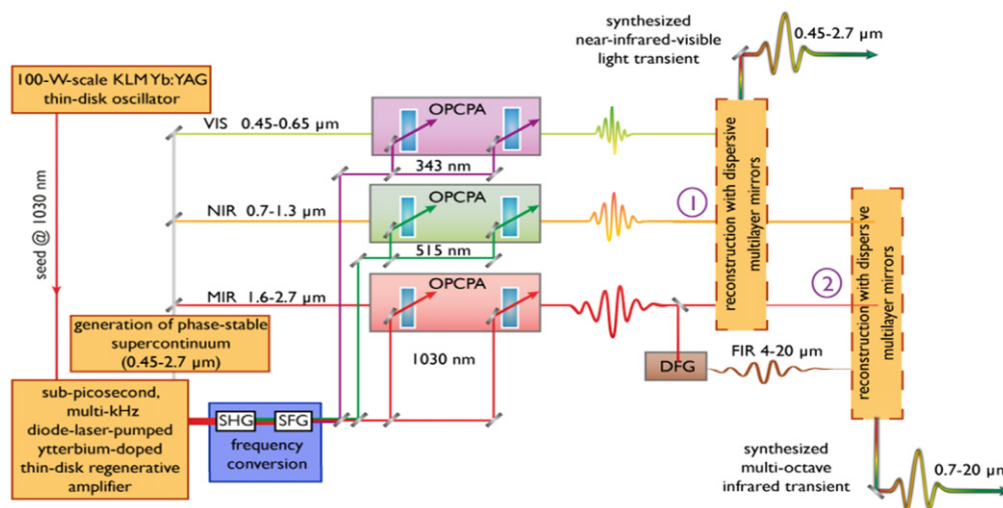

Figure 10. Schematic architecture of a three-channel OPCPA system seeded and pumped by a $1\ \text{ps}$ ytterbium laser. A part of its output is used for generating a phase-stable multi-octave supercontinuum signal, which is split into three channels, centered at $550\ \text{nm}$, $1\ \mu\text{m}$, and $2\ \mu\text{m}$, respectively. The different channels are pumped by different low-order harmonics of the multi-mJ level, kHz, Yb:YAG regenerative amplifier output. Each channel supports few-cycle pulses. By coherently combining the three few-cycle channels in VIS, NIR, and MIR, amplified, non-sinusoidal, multi-octave light transients spanning from 0.45 to $2.7\ \mu\text{m}$ can be generated (1). Extension to FIR can be achieved by intrapulse DFG of the MIR channel. Coherent synthesis of the NIR, MIR and FIR channels will result in unique multi-octave infrared transients with a spectral coverage of $0.7\text{--}20\ \mu\text{m}$ (2). Courtesy of Hanieh Fattahi.

in terms of bandwidth, peak *and* average power and, after femtosecond pulses being generated and amplified in dye and Ti:sapphire lasers, open the era of *third-generation femtosecond technology* (3FST) [98]. The basic architecture of the prototypical 3FST source, which has been dubbed ACCORD, is currently in Garching under construction by a team led by Hanieh Fattahi and Nicholas Karpowicz in close cooperation with Vladimir Pervak and Michael Trubetskov in charge of the development of super-octave chirped mirrors with tailored reflectivity and dispersion [99, 100], as schematically

illustrated in figure 10. Once completed (hopefully in 2017), it will deliver synthesized several-octave light transients [101] with multi-terawatt peak power in the visible–near-infrared (VIS–NIR) wavelength range of $0.45\text{--}2.7\ \mu\text{m}$ and in the near-infrared–mid-infrared range of $0.7\text{--}20\ \mu\text{m}$.

Some of the possible VIS–NIR waveforms, simulated by Hanieh Fattahi, are shown in figure 11. They can—among others—be optimized for extending HHG into the keV regime of photon energies. The generation of isolated attosecond pulses at highest possible photon energies calls for a

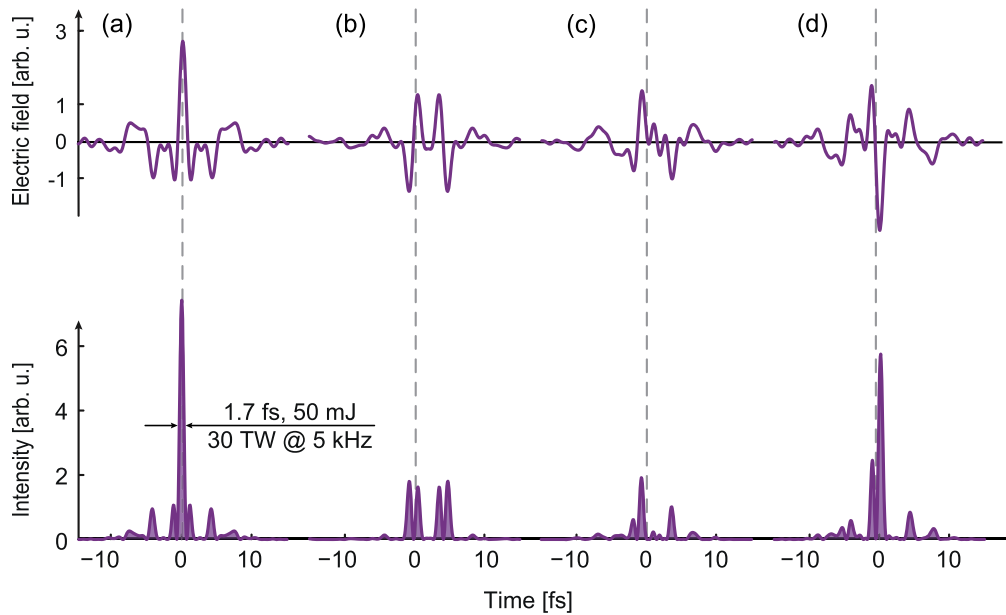

Figure 11. Multi-octave visible-infrared multi-terawatt laser waveforms anticipated from the prototypical three-channel optical parametric amplifier system currently under construction at the Ludwig-Maximilians Universität in Munich and outlined in figure 10. Panel (a) shows the transform-limited waveform that can be constructed from the three channels described in figure 10, whereas (b)–(d) feature a representative set of waveforms that can be created by merely varying the delay between the three OPA channels compressed to their Fourier limit. Courtesy of Hanieh Fattahi.

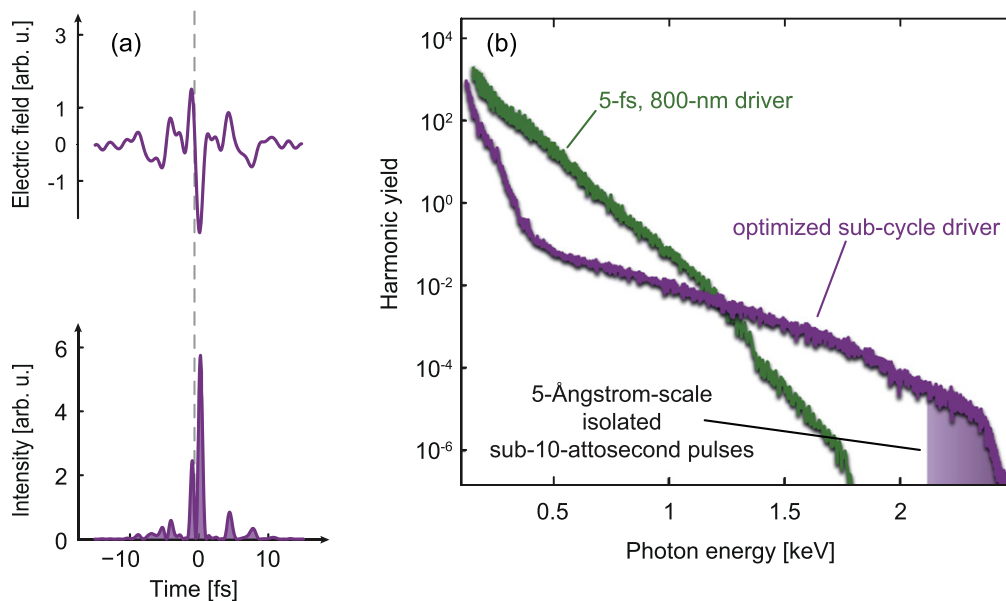

Figure 12. Multi-octave VIS-IR waveform from the multi-channel optical parametric amplifier-synthesizer system sketched in figure 10 optimized for generating high-order harmonics at the highest possible photon energy with the highest possible efficiency. The optimized near-single-cycle waveform dramatically extends the cut-off as compared to a 5 fs, 800 nm driver pulse of the same peak power (and hence larger pulse energy). This is due to the reduced ionization and better resultant phase matching, owing to the abrupt turn-on of the strong field in the single-cycle waveform. The simulation predicts the generation of 10 fs scale isolated attosecond pulses at wavelengths of 0.5 nm.

waveform consisting of a single field cycle, with its first half pushing electrons away from their parent ions and its second half pulling them back. Radiation before this time window would cause undesirable pre-ionization of the atoms in the interaction medium, reducing HHG efficiency due to impaired phasematching and/or depletion of the ground state. A multi-octave bandwidth is a necessary prerequisite for realizing the

ideal, abrupt turn-on of the field amplitude within a fraction of the optical cycle. Figure 12 compares the HHG spectra yielded by the numerical studies of Hanieh Fattahi and Marcelo Ciappina for a 5 fs Gaussian driver pulse and a single-cycle VIS-NIR (0.45–2.7 μm) driving waveform of the same peak intensity. The optimum waveform that our algorithm has found so far, indeed, carried most of its energy in a single

intense wave cycle, which is turned on as abruptly as possible with the available bandwidth.

The predicted isolated 2.5 keV attosecond pulses will provide access to both strongly bound electronic states and atomic-scale electron trajectories by means of keV attosecond electron spectroscopy and diffraction, respectively. This capability, combined with the ability to induce and control strong-field electron phenomena in dielectrics and semiconductors with the unique multi-octave VIS–NIR and NIR–MIR waveforms, offers extremely exciting research opportunities of fundamental and technological importance likewise.

Outlook

Next-generation femtosecond and attosecond technology promises to dramatically increase the flux and/or photon energy of attosecond light and the bandwidth available for engineering light forces. Orders of magnitude more powerful than nowadays available vacuum/XUV or soft-x-ray attosecond pulses will permit attosecond probing of processes with much smaller cross-sections and attosecond-pump/attosecond-probe spectroscopies of a wide range of bound electron excitation and relaxation dynamics, which are inaccessible today.

On the other hand, extending attosecond pulses (at useful flux levels) to x-ray (several keV) photon energies will allow capturing the picometer-attosecond-scale motions of electrons via attosecond x-ray diffraction.

Direct visualization of dynamic changes in electron density may thereby become feasible in arbitrarily complex systems, providing never-before-attained insight into the working of biological systems at the most fundamental level: at the level of (coupled) electronic and nuclear motions. Last but not least, multi-octave waveforms spanning from the visible (Petahertz) to infrared (Terahertz) spectral range will be instrumental in exploring electron phenomena in semiconductors and dielectrics that may be essential for advancing signal processing and metrology to their ultimate limit, to optical (Petahertz) frequencies. These advances would entail a new revolution in exploring microscopic dynamics. All motions outside the atomic core would, in principle, become accessible and subject to human control to a never-before-achieved extent.

Acknowledgment

The author gratefully acknowledges the support of Mandy Singh and Christian Hackenberger in the final editing of the text and the figures, respectively.

References

[1] Battacherjee Y 2001 *Nature* **412** 474

- [2] Hentschel M *et al* 2001 *Nature* **414** 509
 [3] Krausz F and Ivanov M 2009 *Rev. Mod. Phys.* **81** 163
 [4] Krehl P and Engemann S 1995 *Shock Waves* **5** 1
 [5] Abraham H and Lemoine T 1899 *Compt. Rend.* **129** 206
 [6] Norrish R G W and Porter G 1949 *Nature* **164** 658
 [7] Eigen M 1954 *Discuss. Faraday Soc.* **17** 194
 [8] Zewail A H 1994 *Femtochemistry* vol I and II (Singapore: World Scientific)
 [9] Zewail A 2000 *J. Phys. Chem. A* **104** 5660
 [10] Hänsch T W 1990 *Opt. Commun.* **80** 71
 [11] Farkas G and Tóth C 1992 *Phys. Lett. A* **168** 447
 [12] Harris S E, Macklin J J and Hänsch T W 1993 *Opt. Commun.* **100** 487
 [13] Harris S E and Sokolov A V 1998 *Phys. Rev. Lett.* **81** 2894
 [14] McPherson A *et al* 1987 *J. Opt. Soc. Am. B* **4** 595
 [15] L’Huillier A and Balcou P 1993 *Phys. Rev. Lett.* **70** 774
 [16] Macklin J, Kmetec J D and Gordon C L III 1993 *Phys. Rev. Lett.* **70** 766
 [17] Lewenstein M, Balcou P, Ivanov M Y, L’Huillier A and Corkum P B 1994 *Phys. Rev. A* **49** 2117
 [18] Corkum P B, Burnett N H and Ivanov M Y 1994 *Opt. Lett.* **19** 1870
 [19] Ivanov M Y, Corkum P B, Zuo T and Bandrauk A 1995 *Phys. Rev. Lett.* **74** 2933
 [20] Antoine P, L’Huillier A and Lewenstein M 1996 *Phys. Rev. Lett.* **77** 1234
 [21] Fork R L *et al* 1987 *Opt. Lett.* **12** 483
 [22] Shank C V 1988 *Ultrashort Laser Pulses and Applications (Topics in Applied Physics No. 60)* ed W Kaiser (New York: Springer) p 5
 [23] Moulton P F 1986 *J. Opt. Soc. Am. B* **3** 125
 [24] Spence D E, Kean P N and Sibbett W 1991 *Opt. Lett.* **16** 42
 [25] Strickland D and Mourou G 1985 *Opt. Commun.* **56** 219
 [26] Maine P, Strickland D, Bado P, Pessot M and Mourou G 1988 *IEEE J. Quantum Electron.* **24** 398
 [27] Brabec T and Krausz F 2000 *Rev. Mod. Phys.* **72** 545
 [28] Li X F, L’Huillier A, Ferray M, Lompré L A and Mainfray G 1989 *Phys. Rev. A* **39** 5751
 [29] L’Huillier A, Li X F and Lompré L A 1990 *J. Opt. Soc. Am. B* **7** 527
 [30] L’Huillier A, Schafer K J and Kulander K C 1991 *Phys. Rev. Lett.* **66** 2200
 [31] L’Huillier A, Balcou P, Candel S, Schafer K J and Kulander K C 1992 *Phys. Rev. A* **46** 2778
 [32] L’Huillier A, Lompré L-A, Mainfray G and Manus C 1992 *Atoms in Intense Laser Fields* ed M Gavrilá (New York: Academic) p 139
 [33] Paul P M *et al* 2001 *Science* **292** 1689
 [34] Fork R L, Martinez O E and Gordon J P 1984 *Opt. Lett.* **9** 150
 [35] Martinez O E, Gordon J P and Fork R L 1984 *J. Opt. Soc. Am. A* **1** 1003
 [36] Asaki M T *et al* 1993 *Opt. Lett.* **18** 977
 [37] Proctor B and Wise F 1993 *Appl. Phys. Lett.* **62** 470
 [38] Curley P F *et al* 1993 *Opt. Lett.* **18** 54
 Spielmann C, Curley P F, Brabec T and Krausz F 1994 *IEEE J. Quantum Electron.* **30** 1100
 [39] Szipöcs R, Ferencz K, Spielmann C and Krausz F 1994 *Opt. Lett.* **19** 201
 [40] Stingl A, Spielmann C, Krausz F and Szipöcs R 1994 *Opt. Lett.* **19** 204
 [41] Haus H A, Fujimoto J G and Ippen E P 1992 *IEEE J. Quantum Electron.* **28** 2086
 [42] Brabec T *et al* 1992 *Opt. Lett.* **17** 748
 Brabec T *et al* 1992 *Opt. Lett.* **17** 1292
 [43] Mayer E J, Möbius J, Euteneuer A, Rühle W W and Szipöcs R 1997 *Opt. Lett.* **22** 528
 [44] Kärtner F X *et al* 1997 *Opt. Lett.* **22** 831
 [45] Tempea G *et al* 1998 *J. Sel. Top. Quantum Electron.* **4** 193
 [46] Stingl A *et al* 1995 *Opt. Lett.* **20** 602

- [47] Sutter D H *et al* 1999 *Opt. Lett.* **24** 631
- [48] Ell R *et al* 2001 *Opt. Lett.* **26** 373
- [49] Binhammer T, Rittweger E, Morgner U, Ell R and Kärtner F X 2006 *Opt. Lett.* **31** 1552
- [50] Nisoli M, De Silvestri S and Svelto O 1996 *Appl. Phys. Lett.* **68** 2793
- [51] Nisoli M *et al* 1997 *Opt. Lett.* **22** 522
- [52] Xu L *et al* 1996 *Opt. Lett.* **21** 2008
- [53] Baltuška A *et al* 2003 *Nature* **421** 611
- [54] Hänsch T W 2006 *Rev. Mod. Phys.* **78** 1297
- [55] Ch S *et al* 1997 *Science* **278** 661
- [56] Silberberg Y 2001 *Nature* **414** 494
- [57] Drescher M *et al* 2002 *Nature* **419** 803
- [58] The editors of *Nature* 2002 **420** 737
- [59] The editors of *Science* 2002 **298** 2297
- [60] Kienberger R *et al* 2004 *Nature* **427** 817
- [61] Goulielmakis E *et al* 2004 *Science* **305** 1267
- [62] Cavalieri A *et al* 2007 *Nature* **449** 1029
- [63] Schultze M *et al* 2010 *Science* **328** 1658
- [64] Neppel S *et al* 2015 *Nature* **517** 342
- [65] Johnsson P *et al* 2005 *Phys. Rev. Lett.* **95** 013001
- [66] Remetter T *et al* 2006 *Nat. Phys.* **2** 323
- [67] Mauritsson J *et al* 2008 *Phys. Rev. Lett.* **100** 073003
- [68] Sansone G *et al* 2010 *Nature* **465** 763
- [69] Neidel C *et al* 2013 *Phys. Rev. Lett.* **111** 033001
- [70] Mansson E P *et al* 2014 *Nat. Phys.* **10** 207
- [71] Cavalieri A *et al* 2007 *New J. Phys.* **9** 242
- [72] Schultze M *et al* 2016 private communications
- [73] Niikura H *et al* 2002 *Nature* **417** 917
- [74] Lein M, Hay N, Velotta R, Marangos J P and Knight P L 2002 *Phys. Rev. Lett.* **88** 183903
- [75] Niikura H *et al* 2003 *Nature* **421** 826
- [76] Itatani J *et al* 2004 *Nature* **432** 867
- [77] Meckel M *et al* 2008 *Science* **320** 1478
- [78] Niikura H, Villeneuve D M and Corkum P B 2005 *Phys. Rev. Lett.* **94** 083003
- [79] Kanai T, Minemoto S and Sakai H 2005 *Nature* **435** 470
- [80] Lein M 2005 *Phys. Rev. Lett.* **94** 053004
- [81] Vozzi C *et al* 2005 *Phys. Rev. Lett.* **95** 153902
- [82] Baker S *et al* 2006 *Science* **312** 424
- [83] Smirnova O *et al* 2009 *Nature* **460** 972
- [84] Woerner H J *et al* 2010 *Nature* **466** 604
- [85] Woerner H J *et al* 2011 *Science* **334** 208
- [86] Hammond T J *et al* 2015 *Nature* **522** 462
- [87] Goulielmakis E *et al* 2008 *Science* **320** 1614
- [88] Zhao K *et al* 2012 *Opt. Lett.* **37** 3891
- [89] Uiberacker M *et al* 2007 *Nature* **446** 627
- [90] Goulielmakis E *et al* 2010 *Nature* **466** 739
- [91] Chini M *et al* 2013 *Sci. Rep.* **3** 1105
- [92] Schiffrin A *et al* 2013 *Nature* **493** 70
- Schiffrin A *et al* 2014 *Nature* **507** 386
- [93] Schultze M *et al* 2013 *Nature* **493** 75
- [94] Schultze M *et al* 2014 *Science* **346** 6
- [95] Wirth A *et al* 2011 *Science* **334** 195
- [96] Luu T *et al* submitted for publication
- [97] Thomas Metzger and Nubbemeyer T 2016 private communications
- [98] Fattahi H *et al* 2014 *Optica* **1** 45
- [99] Pervak V *et al* 2007 *Appl. Phys. B* **87** 5
- [100] Chia S-H *et al* 2014 *Optica* **1** 315
- [101] Mücke O D *et al* 2015 *J. Sel. Top. Quantum Electron.* **21** 8700712